

LT200

LOADER MOUNTING

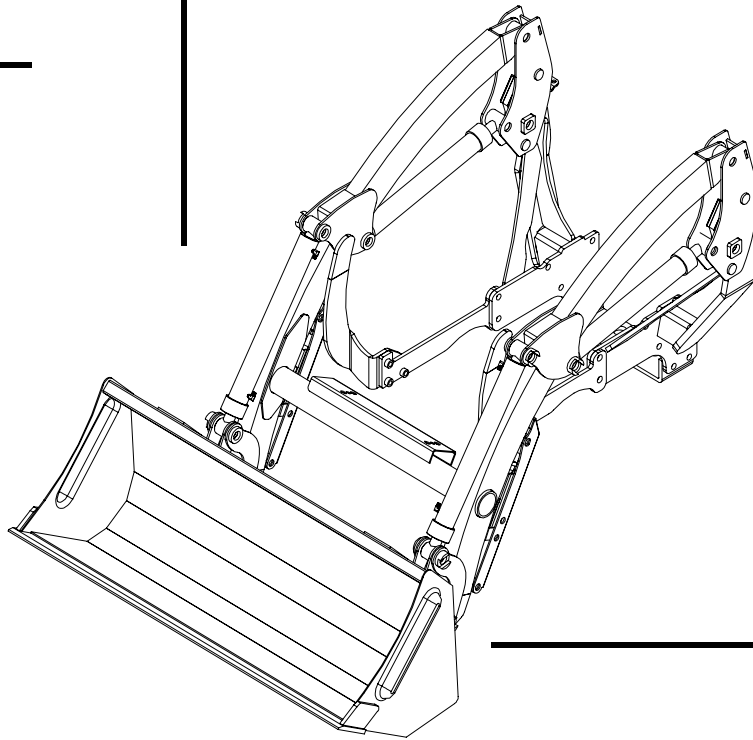

*TYM TRACTOR MODEL
T233, T273*

*INCLUDES;
PARTS CATALOGUE*

WARRANTY CONDITIONS

Warranty Coverage :

TYM Tractor Division, herein referred to as *TYM*, undertakes to replace or repair any part of a *TYM* loader where damage has been proven to be caused by defects in material or workmanship.

This Warranty is valid for a period of 1 year from the date of the original retail sale. Parts replaced or repaired under the terms of this Warranty are guaranteed only until the original warranty expires. Warranty only applies to the original purchaser.

It is further understood and agreed that the defect should be immediately reported to the Selling Dealer. The Selling Dealer will generally perform Warranty repairs or replacements and the Purchaser shall deliver the *TYM* Loader to the Dealer's place of business or repair.

The obligation of *TYM* to the Purchaser under this Warranty is limited to the repair or replacement of defective parts by an authorized *TYM* dealer. Repair or replacement in accordance with this Warranty shall constitute fulfillment of all liabilities of *TYM* and the Selling Dealer in respect to *TYM* Loaders.

There are no warranties beyond those which expressly appear herein. Any implied warranty of merchantability or fitness for a particular purpose is specifically excluded here from.

Warranty Provisions :

TYM's liability under this warranty is subject to the observance by the Purchaser of the following provisions:

- The purchaser shall at all times in the operation of any *TYM* Product, use those brands and grades of lubricating oils, lubricants or fuel and spare parts officially approved by *TYM*.
- The *TYM* Loaders shall have been used in accordance with the procedures specified in the Operator's Manual. This Warranty does not extend to damage resulting from misapplication, abuse, misuse, failure to perform maintenance, negligence, fire, accidents or changes or faulty mounting carried out by the Purchaser. When making a Warranty exchange of parts, the Purchaser shall compensate *TYM* for the time that the parts have been used if they have been exposed to extreme wear.
- Compensation is not paid for physical harm, deadlock, resulting damages or other losses.
- To obtain warranty service, the Purchaser must (1) report the product defect to an authorized *TYM* dealer and request repair within the applicable warranty term and (2) present evidence of purchase.
- The Warranty shall be void if the *TYM* Loader has been altered or repaired outside of a *TYM* dealership or travel of dealer personnel to customer location for Warranty repair. The customer shall also pay any premium for overtime labor requested by the customer.
- Temporary repairs or additional costs due to the work being performed after normal working hours will not be compensated.
- The above warranty is in lieu of all other warranties on *TYM's* behalf and neither party assumes any other liability in connection with *TYM's* Products.

Right To Make Design and Product Changes :

TYM reserves the right to make changes in the design and other changes in its *TYM* Products at any time without incurring any obligation with respect to any product previously ordered, sold or shipped.

PLEASE NOTE :

Make sure all potential of the this equipment review this manual and all safety messages contained within



This safety symbol indicates important safety messages oin this manual. When you see this symbol, carefully read the message that folloes and be alert to the possibility of personal injury or death.

Table of Contents

Safety Precautions	-----	4
Safety Decals	-----	6
Loader Specifications	-----	7
Introduction	-----	8
Tractor Preparation	-----	9
Loader Operation	-----	10
Loader Removal	-----	13
Loader Mounting	-----	14
Lubrication and Maintenance	-----	15
Trouble Shooting	-----	17
Hydraulic System Schematic	-----	21
Torque Tightening Chart	-----	22
Parts Illustrations	-----	23
General Information		23
Earth Bucket		24
Mounting Frame Assembly		25
Boom Assembly		26
Hydraulic Piping		27
Quick Attachment		28
Hydraulic Connecting		30
Boom Cylinder		31
Bucket Cylinder		32
Decals		33
Loader Installation	-----	34

SAFETY

Understand that your safety and the safety of other persons is measured by how you service and operate this loader. Know the position and operations of all controls before you they to operate. **Make sure you check all controls in all safe area before starting.**

The safety information given in this manual does not replace any safety codes, insurance needs, federal, state and local laws. Make sure your machine has the correct equipment required by your local laws and regulations.

Read this manual completely and thoroughly and make sure you understand all controls. All equipment has a limit. Make sure you are aware of the stability and load characteristics of this loader before you begin operation.



This safety alert symbol indicates important safety messages in this manual. When you see this symbol, carefully read the message that follows and be alert to the possibility of personal injury or death.



SAFETY PRECAUTIONS



Before starting the engine of your tractor, make sure all operation controls are in park lock or neutral position.

Operate controls only when seated in the operator's seat.

Equip your tractor with a ROPS cab or frame for your protection. See your tractor operator's manual for correct seat belt usage.

A frequent cause of personal injury or death is persons falling off and being run over. Do not permit others to ride on your tractor. Only one person, the operator, should be on the machine when it is in operation.

Before leaving the tractor, stop the engine, put all controls in neutral, engage the parking brake and remove the key from the ignition.

When using remote hydraulic tractor valves on some tractors, the loader lift and dump cylinders will continue moving unless the control levers are manually returned to neutral, or until relief pressure is reached at the ends of piston strokes. Observe the bucket movement and maintain control with the control levers.

Stop the loader arms gradually when lowering or lifting loads.

Stay off of slopes too steep for safe operation. Shift down before you start up or down a hill with a heavy load. Avoid "free wheeling"

Travel speed should be such that complete control and machine stability is maintained at all times. Where possible, avoid operation near ditches, embankments and holes. Reduce speed when turning, crossing slopes, and on rough, slick or muddy surfaces.

Never use your hand to check for suspected leaks under pressure. Use a piece of cardboard or wood for this purpose. Escaping hydraulic oil or diesel fuel leaking under pressure can have sufficient force to penetrate the skin and cause infection or other injured by leaking fluid, seek medical attention immediately.

To prevent personal injury, relieve all pressure before disconnecting fluid lines.

Before applying hydraulic pressure, make sure all hydraulic connections are tight and components are in good condition.

SAFETY

Contact with overhead power lines can cause severe electrical burn or death from electrocution. Make sure there is enough clearance between raised equipment and overhead power lines.

Add recommended rear tire liquid weight or rear wheel weights for increased stability.

A loader attachment should be transported in a low position at slow ground speeds. Make turns slowly and use the tractor brakes cautiously. A loaded attachment in the raised position alters the center of gravity location of the machine and increases the possibility of mishaps.

Do not stand, walk or work under a raised loader or attachment unless it is securely blocked or held in position. Accidental movement of a control lever or leak in the hydraulic system could cause the loader to drop, or attachment to dump, causing severe injury.

Make sure all parked loaders on stands are on a hard level surface with all safety devices engaged to prevent loader from falling and being damaged or injuring someone.

When using a loader, be alert of bucket position at all times. Loader in raised position with bucket rolled back can dump material on tractor causing damage or injury to tractor and / or operator.

Always park loader with bucket attached to loader.

SAFETY DECALS

Safety Decal Locations

Important:

Warning decal CK12-3001, located on the left hand Mid-Mount and Warning Decal CK12-3002, CK12-3003 located on the loader right hand Mid-Mount are visible when getting on tractor.

Care of Safety Decals.

1. Keep safety decals clean and free of obstructing material.
2. Clean safety decals with soap and water and dry with a soft cloth.
3. If a component with a safety decal(s) affixed is replaced with a new part, make sure new safety decal(s) are attached in the same location(s) as the replaced components.
4. Mount new safety decals by applying on a clean dry surface and pressing air bubbles to outside edges.



Warning CK12-3001

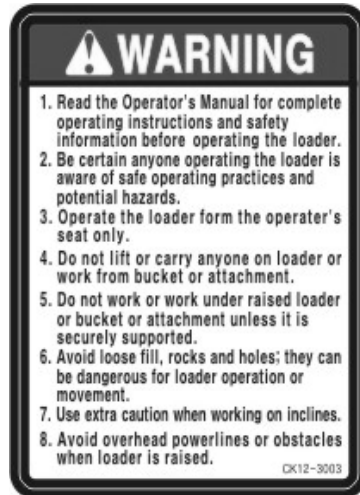

Warning CK12-3003



Warning CK12-3002



TYM00-20051

QUALITY MATTERS

LTL16-TYM00

TYM LT200

LTL16-LT200

LOADER SPECIFICATION

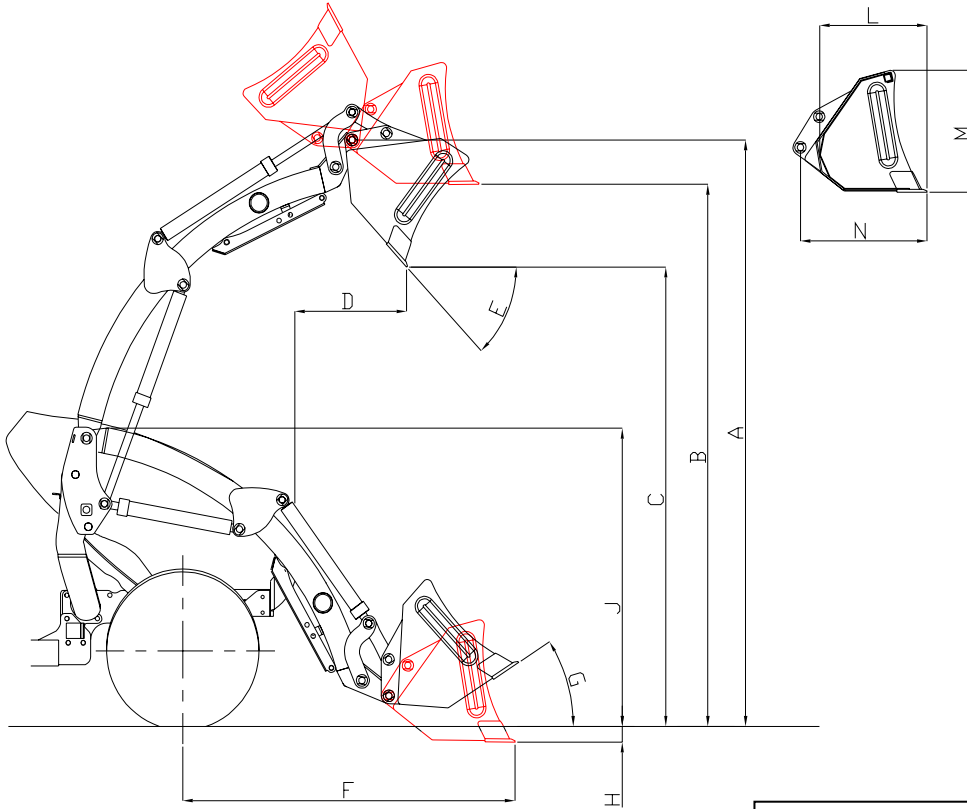

Specifications and design are subject to change without prior notice.

Loader Model : LT200
 Tractor Model : T233 / 273
 Front Tire : 23x8.50-12
 Rear Tire : 12-16.5
 with out self leveling type

A. Maximum Lift Height	2,238 mm	88.1 "
B. Clearance with Attachment Level	2,067 mm	81.4 "
C. Clearance with Attachment Dumped	1,750 mm	68.9 "
D. Reach at Maximum Height(45°)	490 mm	19.3 "
E. Maximum Dump Angle	47 °	47 °
F. Reach with Attachment on Ground	1,331 mm	52.4 "
G. Attachment Rollback Angle	35 °	35 °
H. Digging Depth Below Grade	80 mm	3.1 "
J. Overall Height in Carry Position	880 mm	34.6 "
L. Depth of Attachment (to back of inner shell)	450 mm	17.7 "
M. Height of Attachment	470 mm	18.5 "
N. Depth of Attachment (to pivot pin)	507 mm	20.0 "
Lift Capacity to Full Height at Pivot Pins	612 kgf	1,349 lb
Breakout Force at Ground Level, Pivot Pins	782 kgf	1,723 lb
Relief Valve Setting (Loader Control Valve)	2,300 psi	2,300 psi
Rated Flow (Tractor System)	28.9 l/min.	7.64 gpm
Lift Cylinder	Ø45x350 mm	Ø1.77X13.8 "
Bucket Cylinder	Ø45x330 mm	Ø1.77X13.0 "
Attachment used for specification	1,270 mm	50 "
Hydraulic System	Tractor pump w/loader control valve	
-Standard : Bucket Level indicator		

INTRODUCTION

The purpose of this manual is to assist you in maintaining and operating your loader. Read it carefully, it furnishes information and instructions that will help you achieve years of dependable performance. Some information may be general in nature due to unknown and varying conditions. However, through experience and these instructions, you should be able to develop operating procedures suitable to your particular situation.

"Right" and "Left" as used throughout this manual are determined by facing the direction the machine will travel when in use.

The photos, illustrations and data used in this manual are current at the time of printing, but due to possible in-line production changes, your machine may vary slightly in detail. The manufacturer reserves the right to redesign the machine as may be necessary without notification.

Important:

Illustrations used in this manual may not show all safety equipment that is recommended to ensure safe operation of tractor and loader. Refer to the Safety Precautions section of this manual for information concerning safety. consult your dealer for further information.

Warranty Registration

The Delivery and Warranty Registration forms must be filled out and signed to validate your warranty protection. The items on the form under "I hereby Acknowledge" should be read and understood. The terms and conditions of the warranty on this machine are specified in the front of this manual.

Serial Number and Location

The serial number is important information about the machine and it may be necessary to know it before obtaining the correct replacement part. The serial number plate is located on the LH(left hand) inside of front area of boom. The serial number should be recorded on the Delivery and Registration form and also below for your reference.

Loader Serial Number Information

Date Purchased _____

Loader Serial Number _____

Dealer Name and Telephone Number _____

TRACTOR PREPARATION

Rear Counterweight



CAUTION:

Add recommended rear tire liquid weight, rear wheel or rear ballast for increased stability.



CAUTION:

Do not exceed the manufacturer's rating for maximum gross vehicle weight. Refer to Operator's Manual or ROPS serial plate provided with tractor.

The use of adequate counterweight to counter balance for maximum loader capacity is required for safe loader operation.

Weight added to rear of the tractor provides better traction and easier, more efficient loader operation. The tractor can be counter weighted by filling rear tires with liquid calcium solution and/or by the installation of rear wheel weights.

Additional counterweight requirements will vary with loader attachments and equipment applications. Additional weight can be added by installation of Three Point Hitch mounted ballast.



CAUTION:

The tractor/loader must only be operated with all safety equipment properly installed.

TRACTOR TIRES

Selection of tires(size, profile, tread type) should be restricted to tire recommendations as specified by *TYM*.

Tire Inflation

Front tires must be maintained at the maximum recommended inflation to maintain normal tire profile with the added weight of loader/material.

Rear tires must be maintained at equal pressure within the recommended tire inflation range. Unequal rear tire inflation can prevent loader attachment from contacting the ground across its full width.



CAUTION:

Certain specific conditions may not permit safe use of loader at loader rating or may require more careful restricted operation at the rated load.

Refer to Tractor Operator's Manual for specific recommendations on counterweight tractor.

ROPS System

The tractor must be equipped with an approved ROPS System to ensure adequate operator's protection.

Tractor Hydraulic System

Tractor operation in a loader application significantly increase demands on the tractor Hydraulic System. Check the tractor Hydraulic system fluid level daily. Refer to your tractor Operator's Manual maintenance section for instructions regarding tractor hydraulic system maintenance.

Adhere to recommendation in your Tractor Operator's Manual concerning hydraulic fluid and filter specifications, and change intervals.

Wheel Tread Settings

Tractor front wheel tread setting must be restricted to wheel tread spacing recommended in the tractor Operator's Manual.

Front Counterweight

Use of front counterweight is not recommended when tractor is being used in a loader application. Front counterweight adds unnecessary front axle load in loader applications.

LOADER OPERATION



CAUTION:

The tractor/loader should only be operated with all safety equipment properly installed.

Precautionary Notes

Do not lower the edge of the bucket too low for loading. Keep the bottom of the bucket level with the ground when loading.

Important: Do not use the bucket for pushing down material with bucket cylinders partially extended. Damage to the cylinders may result.

Important: Do not tip bucket cutting edge down (fully extended bucket cylinders) during backfilling/backgrading operations.

Important: Operation with front tractor wheels off the ground is not recommended.

Position vehicle to be loaded as near the pile as possible and in such a direction as to minimize the amount of tractor turning required to dump.

Do not lower the loader with the tractor engine shut off.

Keep the unit clean and perform regular service. Observe safety messages whenever cleaning, servicing, or lubricating.

We urge you to follow this advice:

1. Read and understand this manual as well as the Tractor Operator's Manual.
2. Remember and observe the Safety Precautions brought to your attention in this manual, the tractor manual and on the machinery itself.
3. Use good common sense in the everyday operation of this unit. Safety recommendations can never be all-inclusive and you are responsible for watching out for and avoiding unsafe conditions.
4. Never exceed the limits of a piece of machinery. If its ability to do a job or to do so safely is in question, don't try it.

5. Don't hurry the learning process or take the unit for granted. Ease into it and become familiar with your new loader and tractor.



CAUTION: When lowering a heavy load,

ease it downward slowly. Never drop a loaded attachment and "catch it hydraulically". Stopping a load after it has gained downward momentum places undue strain on the unit and may cause unnecessary damage to the loader or tractor or even worse, personal injury.



CAUTION: Before disconnecting hydraulic lines, relieve all hydraulic pressure.

Escaping hydraulic oil under pressure can have sufficient force to penetrate the skin causing serious personal injury. If injured by escaping hydraulic oil seek medical attention immediately.



CAUTION: Do not operate the loader if

the fittings are leaking or if the hoses are damaged. A sudden line burst would cause the mainframe to drop suddenly, causing damage to the tractor or loader or injury to personnel.

Initial Loader Operation

Before operating the loader, fully raise and lower the boom two or three times. Then raise the bucket approximately four(4) feet above the ground and cycle the bucket cylinders three times. Lower the bucket to the ground. Check the tractor hydraulic oil and the correct oil level.



CAUTION:

Before leaving the machine, stop the engine, remove the key, place all controls in neutral, and either set the parking brake or place tractor in park as equipped.

Always keep cylinders in a retracted position when the loader is not in use to guard against rust and contamination which may cause damage to the cylinder rods or hydraulic system.

Cold Weather Operation

For smooth operation in cold weather, let the tractor warm up. Slowly cycle the lift and bucket cylinders several times to warm the oil in the hydraulic system. The loader may operate erratically until the hydraulic oil has warmed to operating temperatures.

LOADER OPERATION



CAUTION:

Operate controls only when seated in the operator's seat.

Loading Bucket

For the most efficient loading, slowly drive the tractor straight into the material to be loaded and increase speed only after contact has been made. Roll the attachment back a small amount and slowly lift to break away the material. As the load increase, continue rolling the attachment back so as to get the maximum load. Remove the top levels first when loading from large piles of material. When bucket is full, raise loader so the bucket is clear of material and slowly back out of the pile.

Dumping Bucket

When in the dump area slowly drive the tractor forward and raise the loader at the same time. Raise the loader to the height needed to dump the bucket. Make sure to keep a level bucket position to prevent spilling from the bucket. Dump the bucket, and keep all movements smooth.

Transporting a Loaded Bucket

Transport material with the bucket as low as possible to prevent spilling and keep maximum stability. The loader must be in a position that will not block the operators' vision. a loaded bucket must not be transported in the upright position or at excessive speed.

Observe the following safety warning when transporting a loaded bucket.



CAUTION:

When using a loader, be aware of bucket location at all times. When raising a loader with bucket rolled back, material can dump onto tractor causing damage to tractor or injury to operator.



WARNING:

Contact with overhead power lines can cause severe electrical burns or death from electrocution. Make sure there is clearance between raised equipment and over head power lines.



CAUTION:

Stop the loader arms gradually when lowering or lifting.



WARNING:

A loaded Bucket should be transported in a low position at low ground speeds. Make turns slowly and use the tractor brakes cautiously. A full bucket in the raised position alters the center of gravity location of the machine and increases the possibility of accidents.



CAUTION:

Do not stand, walk or work under a raised loader unless it is securely blocked or held in position. Accidental movement of a control lever or leak in th hydraulic system could cause the loader to drop, or attachment to dump, resulting in serious injury or death.

Scraping

When scraping, the Boom lever must be used to keep the bucket on the ground horizontally. The bucket must be kept level to the ground during scraping operations.

Backfilling/Backgrading

When "Backfilling" or "Backgrading", position the bucket so it is level on the ground. Do not dump material from bucket following each pass, as additional weight of material in bucket will assist in "Backgrading" and increases loader efficiency during "Backfilling".

Controlled Rate of Loader Functions

By "feathering" the control lever, reduced operational speeds can be controlled. This action controls the position of the valve spool in the valve body and regulates flow of oil to/from cylinders. It is important utilize this operational practice when lowering loader boom when the bucket is loaded with material.

LOADER OPERATION

Loader Hydraulic Controls

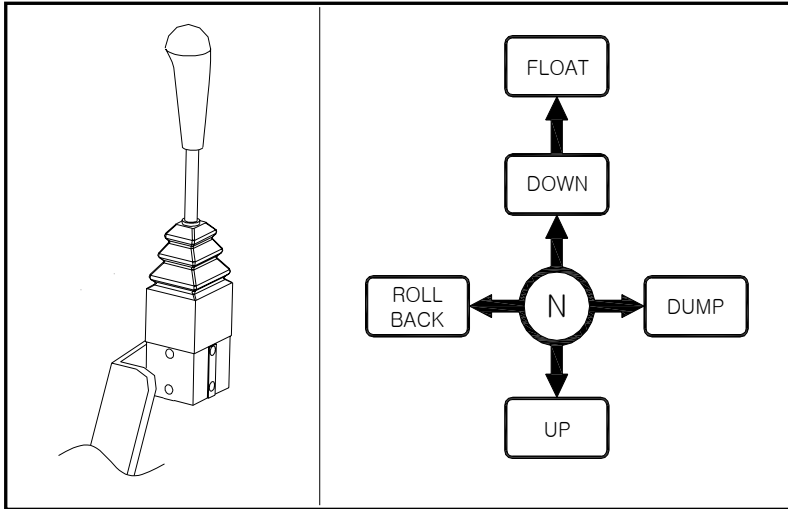

The Single lever joystick control lever is mounts on the LT200 From the factory.
The control lever has the safety lock function.
Lock the control lever when leaving the tractor while the Bucket is in the air.

The loader hydraulic valve lift Cylinder circuit incorporates a "float" position which allows the loader bucket to follow ground contours. The "float" position is engaged by shifting the control lever forward into "detent" until the operator pulls the control lever out of the "Detent" position.

Refer to "Scraping" operation for recommended use of "float" position.

The control valve has a neutral position that prevents movement of loader or bucket.
When the control valve is released from the work position, the spool will return to neutral.

Important:

Contaminates in hydraulic oil can cause valve spools to stick. Be alert when operating loader and follow your Tractor Operator's Manual maintenance schedule.

LOADER REMOVAL



CAUTION:
Never park loader without bucket attached to the loader.



CAUTION:
Never allow weight of tractor to be put on parking leg when removing loader.

STEP 1. Park the tractor and loader on hard level surface.

STEP 2. Raise the boom until the bucket is about 2 feet off the ground.

STEP 3. Set the parking legs with pivot pin and Keeper.

STEP 4. Lower the boom until the Parking legs make contact on the ground. Tip the bucket until the bucket cutting edge touch the ground.

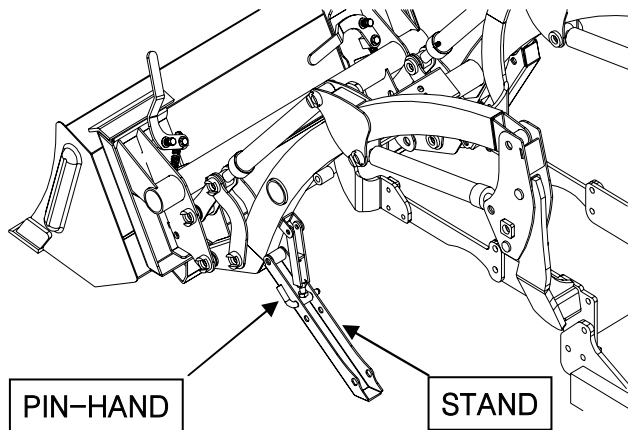

STEP 5. Remove the latch pin while move the control lever back and forth slightly to make the latch pin easy.

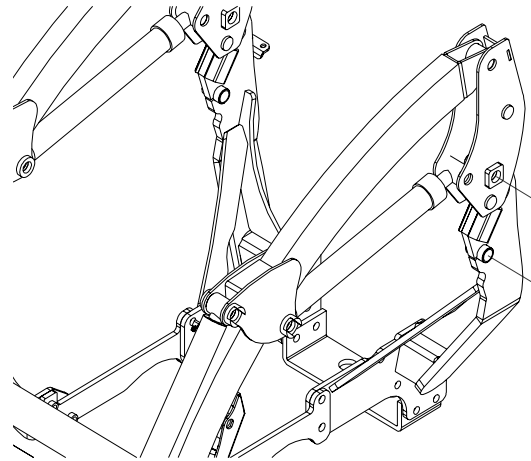
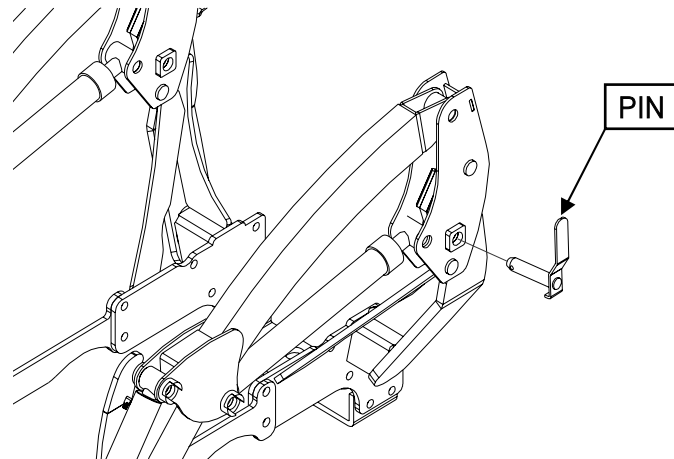

STEP 6. Pull the control lever to raise the loader until the post.

Adjust the bucket until the bottom surface of bucket touch the ground.

STEP 7. Move the tractor backward slowly and stop to avoid the hydraulic hoses being tighten.

STEP 8. Stop the engine and move the control lever back and forth, left and right several times to reduce the hydraulic pressure in the hoses.

STEP 9. Disconnect the quick couplers on the hydraulic hoses.

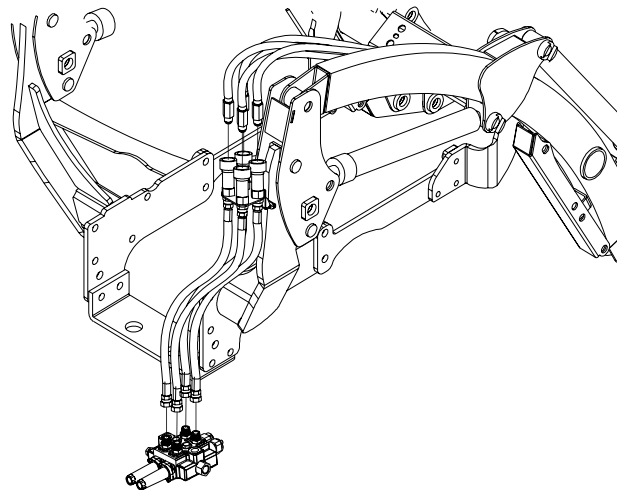

LOADER MOUNTING



CAUTION:

Never allow weight of tractor to be put on parking leg when mounting loader.

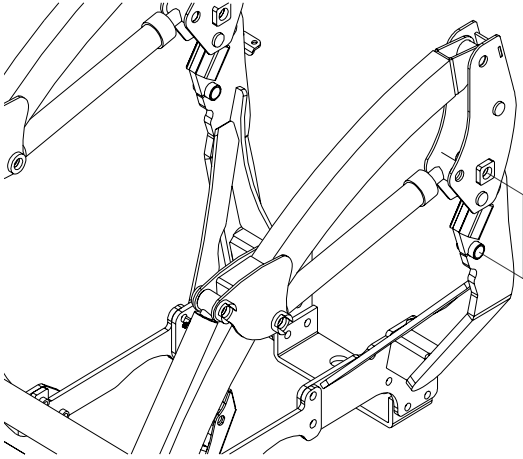

STEP 1. Carefully drive the tractor into the loader to a position where the hydraulic hoses(Quick coupler) can be connected to the control valve block.

STEP 2. Stop the engine and move the control lever back and forth, Left and right several times to reduce the pressure in the hydraulic hoses. Connect the hydraulic couplers match the color code rings.

STEP 3. Start the engine and move the boom and bucket to adjust the height of post.

Be sure to check the hook of inner mounting frame is slightly higher than the pin welded on mounting frame.

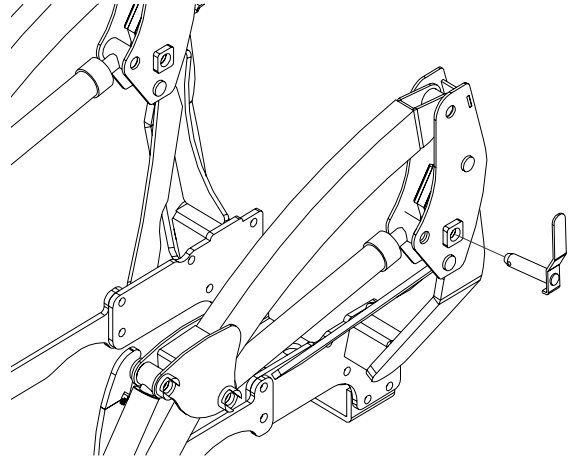

STEP 4. Move the tractor forward to put the inner mounting frame into the mounting frame. Stop the tractor When the hook is right over the pin. Lower the inner mounting frame with moving the boom and bucket until it hooked securely each other.

STEP 5. Align the latch pin holes with moving the bucket and boom. Insert the latch pins. Rubber hammer can be used to put the pin in if needed.

STEP 6. Remove pin and keeper holding the parking legs and return to storage position. Make secure by using pin and keeper.

LUBRICATION AND MAINTENANCE



CAUTION:

Do not perform and service or maintenance Operations with loader raised off the ground. For additional access to tractor components remove loader.

Important:

Lower the loader to the ground and relieve pressure in loader hydraulic lines prior to performing any service or maintenance operations on the tractor or loader.



CAUTION:

Escaping fluid under pressure can have sufficient force to penetrate the skin, causing serious injury. Before disconnecting lines, be sure to relieve all pressure. Before applying pressure to the system, be sure all connections are tight and that lines, pipes and hoses are not damaged. Fluid escaping from a very small hole can be almost invisible. Use a piece of cardboard or wood rather than your hands to search for suspected leaks. If injured by escaping fluid, seek medical attention immediately. Serious infection or reaction can develop if correct medical treatment is not administered immediately.

Refer to "Lubrication and Maintenance Chart" for quick reference to Maintenance Operations.



CAUTION:

Do not operate the loader if the fittings are leaking or if the hoses are damaged. A sudden line burst could cause the mainframe to drop suddenly, causing damage to the tractor or loader or injury to personnel.



CAUTION:

Operate the loader from the tractor seat only.



CAUTION:

Do not stand or walk under a raised loader. Accidental movement of control lever or leak in hydraulic system could cause mainframe to drop, causing severe injury.

Check the tractor hydraulic system as outlined in the Tractor Operator's Manual.

Note:

When checking hydraulic system oil level, the loader should be on the ground and bucket fully retracted(all cylinders in retracted position).

Grease all loader pivot points daily(10 hours). Refer to Tractor Operator's Manual for lubricant recommendations.

Inspect hydraulic hoses, connections, control valve and cylinders for evidence of leakage.

Tractor tires should be maintained at maximum recommended inflation to maintain normal tire profile with added weight of loader/material. Unequal rear tire inflation can result in bucket not being level to the ground.

LUBRICATION AND MAINTENANCE

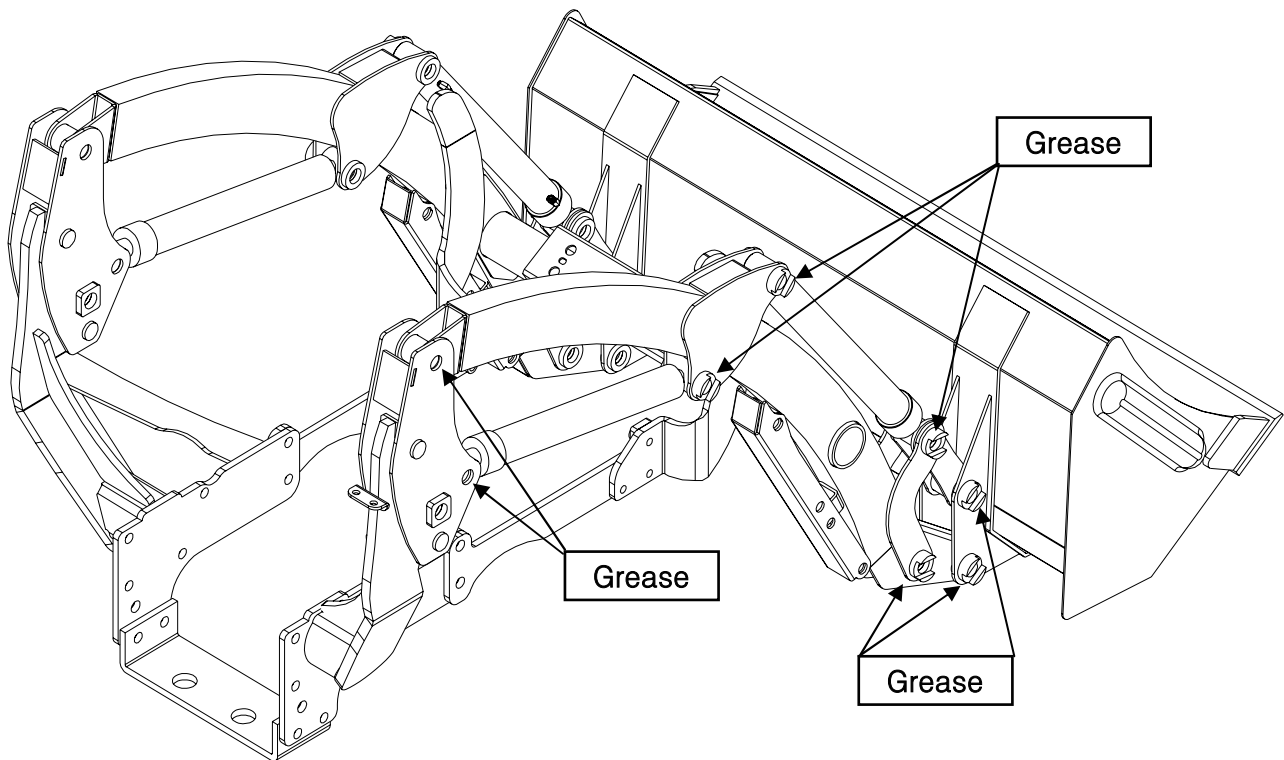

ITEM	SERVICE	SERVICE INTERVAL
Hydraulic System Oil Level	Check	Daily/10 hours
Hydraulic System Oil/Filter	Replace	As specified in Tractor Operator's Manual
Tire Inflation	Check	Weekly/50 hours
Loader Pivot Points	Lubricate	Daily/10 hours
Loader Hydraulic Lines, Hoses, Connections	Check for leaks, wear	Daily/10 hours
Lift and Bucket cylinder rod packings	Check for seepage, service as needed	Daily/10 hours
Pivot pin bolts and dust covers	Check, replace if missing	Daily/10 hours
Mid-Mount latch and lynch pins	Check, replace if necessary	Daily/10 hours
Loader mount hardware	Check visually	Daily/10 hours
Loader mount hardware	Re-torque	Every 25 hours

TROUBLE SHOOTUNG

This Trouble Shooting Chart is provided for reference to possible loader operational problems.

Determine the problem that best describes the operational problem being experienced and eliminate the possible causes as listed by following the correction procedures.

PROBLEM	POSSIBLE CAUSE	CORRECTION
Lift and Bucket Cylinders	Low hydraulic fluid level.	Check and replenish hydraulic fluid.
	Hydraulic hoses connected improperly.	Check and correct hydraulic hose connections.
	Hydraulic hoses to/from control valve blocked	Check for damage(kinked) hoses, etc.
	Loader control valve or tractor main relief valve stuck open.	Check system pressure. Repair or replace relief valve.
	Low system pressure supplied from hydraulic pump.	Check system pressure. Repair or replace pump.
	Control valve linkage broken.	Inspect. Repair as required.
	Quick disconnect coupler(s) are not fully connected or "Flow Check"	Check coupler connections. Replace coupler(s) if necessary.
	Hydraulic hose or tubeline blockage.	Check for evidence of damage to hoses or tubelines that would block flow of oil between cylinders and control valve.
	Cylinder piston assembly defective(not sealing)	Check cylinders for internal leakage as described in service section under cylinder leakage tests.
	control valve blockage.	Inspect for blockage. Disassemble valve if necessary.
Lift and/or Bucket Cylinders operate in wrong direction relative to control valve lever position.	Hydraulic hoses connected incorrectly.	Correct hydraulic hose connections.
Aeration of Hydraulic Fluid(Generally indicated by foamy apperance of fluid).	Low hydraulic fluid level.	Check and refill hydraulic system to proper level.
	Air leaking into suction side of hydraulic pump.	Check for loose or defective connections between reservoir and hydraulic pump.
	Hydraulic fluid foaming due to improper hydraulic oil usage.	Refer to Tractor Operator's Manual and replace hydraulic oil using recommended hydraulic oil.

TROUBLE SHOOTUNG

PROBLEM	POSSIBLE CAUSE	CORRECTION
Slow or erratic lift	Low hydraulic fluid level.	Check and replenish hydraulic fluid.
	Cold hydraulic fluid.	Allow hydraulic system to warm up to operating temperature.
	Engine R.P.M. too slow(hydraulic pump R.P.M. too slow).	Increase engine speed to obtain satisfactory loader operation.
	Excessive weight in bucket. Material weight exceeds maximum specified loader capacity.	Reduce material load.
	Control valve linkage binding/defective.	Check control valve linkage and repair if worn/defective.
	Aeration of hydraulic fluid	Refer to "Aeration of Hydraulic Fluid".
	Quick disconnect coupler restriction or coupler "Flow checks"	Check coupler connections. Repair or replace.
	Hydraulic hose or tubeline restriction(hoses/tubline) kinked or pinched.	Check hoses and tubelines for evidence of restriction.
	Lift cylinder piston assembly leakage.	Check cylinders for leakage. Repair as needed.
	Relief valve erratic or set below specifications.	Check and reset relief valve. Setting as needed.
	Control valve leaking internally.(hypassing fluid within valve).	Replace control valve and recheck operation.
Inadequate hydraulic pump capacity.	Refer to "Hydraulic Pump Capacity Inadequate"	
Inadequate lifting capacity	Engine R.P.M. too slow.	Increase engine R.P.M.
	Excessive load – material weight exceeds specified loader capacity.	Reduce Load.
	Relief valve setting below specifications.	Check and reset relief valve setting as needed.
	Lift cylinder piston assembly leakage.	Check cylinders for leakage. Repair as needed.
	Control valve leaking internally	Replace control valve and recheck operation.
	Hydraulic pump defective.	Refer to "Hydraulic Pump Capacity Inadequate".

TROUBLE SHOOTUNG



PROBLEM	POSSIBLE CAUSE	CORRECTION
System relief valve squeals.	Cold Hydraulic Fluid.	A low hydraulic fluid to warm up to operating temperature.
	Excessive load in bucket. Weight exceeds specified loader capacity.	Reduce load.
	Relief valve setting below specifications.	Check and reset valve setting as needed.
	Hydraulic hose, tubeline or quick disconnect coupler restriction.	Check for evidence of restriction in hydraulic oil flow. Repair or replace defective components.
Loader drops with control valve spool in "centered" position (no external oil leakage evident.) Note: A gradual drop over an extended period of time is a normal condition.	Cylinder piston assembly leakage.	Check cylinders for leakage.
	Control valve internal leakage.	Replace control valve and recheck.
Control valve spool(s) will not return to centered position.	Control lever linkage binding.	Determine origin of binding and repair.
	Control valve spool centering is broken.	Replace centering spring.
	Control valve spool binding in valve body spool bore.	Disassemble valve for inspection and repair.
External hydraulic fluid leakage.	Loose hydraulic connection.	Tighten loose connections.
	Defective hydraulic hose, tubeline, adapter fitting or adapter fitting o-ring.	Check for origin of oil leak and replace defective part.
	Control valve o-rings defective.	Replace defective o-rings.
	Control valve spool or body damaged or worn.	Replace control valve.
	Cylinder rod packing set leakage.	Check cylinders for leakage. Repair as needed.

TROUBLE SHOOTUNG

PROBLEM	POSSIBLE CAUSE	CORRECTION
Hydraulic pump capacity inadequate.	Cold hydraulic fluid.	Allow hydraulic fluid to warm up to operating temperature.
	Engine R.P.M. too slow.	Increase engine R.P.M.
	Low hydraulic fluid supply.	Refer to Tractor Operator's Manual for service recommendations.
	Hydraulic hose restriction.	Check for evidence of restriction in hydraulic hoses.
	Hydraulic pump defective.	Refer to Tractor Operator's Manual for recommended service procedures. Replace hydraulic pump if determined to be defective.
Lift cylinder rod bend when lift cylinders extended.	Excessive shock load on lift cylinders during transport.	Replace defective parts. Review and observe proper and safe operational practices.
Bucket cutting edge wear is uneven side to side	Bucket is not level to ground.	Check rear tire inflation and adjust to level bucket to ground.
Bucket cutting edge wear rate is excessive. (Wear rate is even across full width of bucket). Note: Extensive use of bucket on concrete or asphalt surfaces will accelerate wear rate of bucket cutting edge.	Incorrect operational practices. Excessive down pressure placed on bucket when being used on hard abrasive surfaces.	Refer to operation-scraping section for correct operating procedures. Utilize float position.
	Bucket wear pads worn.	Replace wear pads.

TORQUE TIGHTENING CHART

Note : Use these torques, unless special torques are specified. Values are for UNF thread fasteners, plated or unplated as received from supplier. Fasteners can be dry or lubricated with normal engine oil. Values do not apply if graphite, moly-disulphide or other extreme pressure lubricant is used.



SAE Grade No.	2				5				8*			
Bolt head identification (see note 1)												
Bolt size	LB FT		Nm		LB FT		Nm		LB FT		Nm	
	Min	Max	Min	Max	Min	Max	Min	Max	Min	Max	Min	Max
1/4	5	6	7	8	9	11	12	15	12	15	16	20
5/16	10	12	14	16	17	20.5	23	28	24	29	33	39
3/8	20	23	27	31	35	42	48	57	45	54	61	73
7/16	30	35	41	47	54	64	73	87	70	84	95	114
1/2	45	52	61	70	80	96	109	130	110	132	149	179
9/16	65	75	88	102	110	132	149	179	160	192	217	260
5/8	95	105	129	142	150	180	203	244	220	264	298	358
3/4	150	185	203	251	270	324	366	439	380	456	515	618
7/8	160	200	217	271	400	480	542	651	600	720	814	976
1	250	300	339	406	580	696	787	944	900	1080	1220	1464
1 1/8					800	880	1085	1193	1280	1440	1736	1953
1 1/4					1120	1240	1519	1681	1820	2000	2468	2712
1 3/8					1460	1680	1980	2278	2380	2720	3227	3688
1 1/2					1940	2200	2631	2983	3160	3560	4285	4827

Note 1: Bolt head identification marks as per grade. Manufacturing marks will vary.

*Thick nuts must be used with Grade 8 bolt

METRIC FASTENER (ISO) TORQUE CHART

Note : Use these torques, unless special torques are specified. Values are UNC and UNF thread fasteners, plated or unplated as received from supplier. Fasteners can be dry or lubricated with normal engine oil. Values do not apply if graphite, moly-disulphide or other extreme pressure lubricant is used

ISO Class No.	8.8				10.9				12.9			
Bolt head identification (see note 1)												
Bolt Size	Nm		LB FT		Nm		LB FT		Nm		LB FT	
	Min	Max	Min	Max	Min	Max	Min	Max	Min	Max	Min	Max
M4	3	4	2	3	4	5	3	4	Because of the low ductility of these fasteners, the torque range is to be determined individually for each application. As a general rule, the torque ranges specified for grade 10.9 fasteners can be used satisfactorily on 12.9 fasteners *M14 is not a preferred size.			
M5	6.5	8	5	6	9.5	11	7	8				
M6	10.5	12	8	9	15	17.5	11	13				
M8	26	31	19	23	37	43	27	32				
M10	52	61	38	45	73	87	54	64				
M12	90	107	66	79	125	150	93	112				
*M14	144	172	106	127	200	245	149	179				
M16	217	271	160	200	310	380	230	280				
M20	434	515	320	380	610	730	450	540				
M24	675	815	500	600	1050	1275	780	940				
M30	1250	1500	920	1100	2000	2400	1470	1770				
M36	2175	2600	1600	1950	3500	4200	2580	3090				

Note 1: Bolt head identification marks as per grade. Manufacturing mark will vary.

PART ILLUSTRATIONS

GENERAL INFORMATION

Illustrations

The individual parts in their normal relationship to each other. Reference numbers are used in the illustrations. These numbers correspond to those in the "Number" column and are followed by the quantity required and description.

Directional Reference

"Right hand" and "left hand" sides are determined by standing at the rear of the unit and facing in the direction of forward travel.

Part Order

Orders must give the complete description, correct part number, the total amount required, the product model, all the necessary serial numbers, the method of shipment and the shipping address.

EARTH BUCKET

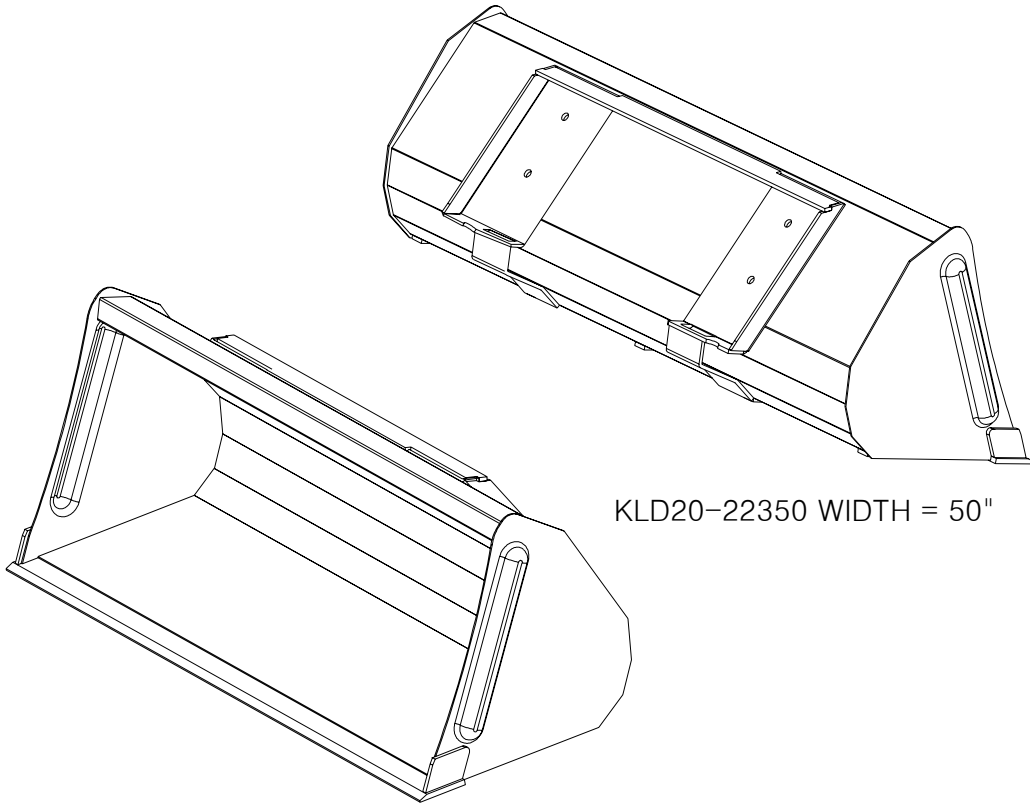

KLD20-22350 WIDTH = 50"

MOUNTING FRAME ASSEMBLY

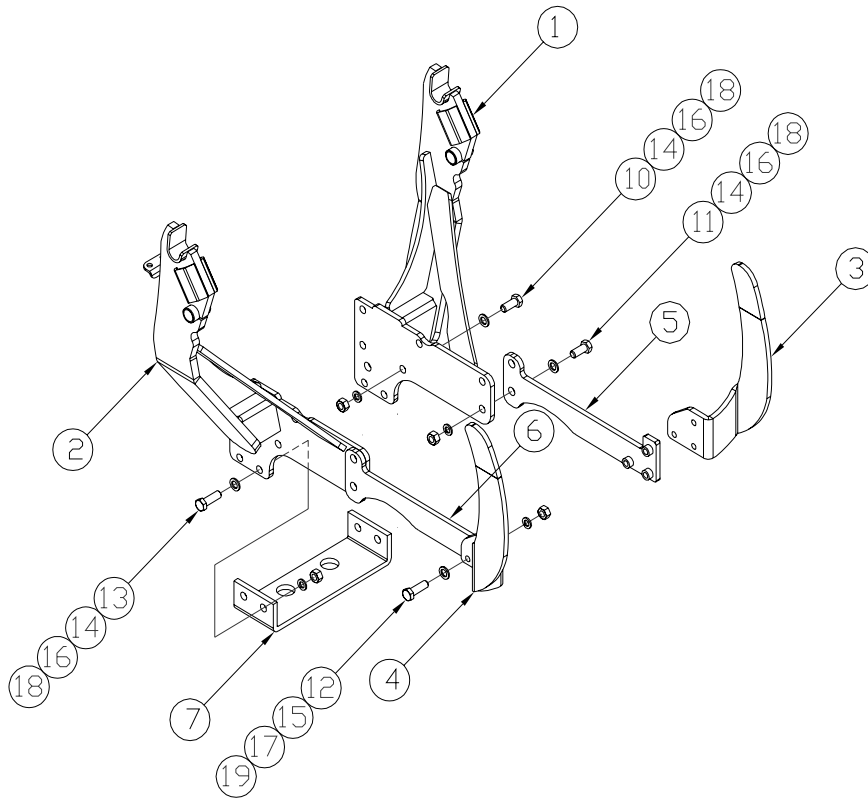

NO.	PART NO.	DESCRIPTION	Q'TY	SERIAL NO.
1	LYS11-11300	BODY SUPPORT W.A_LH	1	
2	LYS11-11400	BODY SUPPORT W.A_RH	1	
3	LYS11-12110	GRILLE_LH	1	
4	LYS11-12120	GRILLE_RH	1	
5	LYS11-12210	GRILLE CONNECTOR_LH	1	~51005048
	LYS11-12210A		1	51203001~
6	LYS11-12220	GRILLE CONNECTOR_RH	1	~51005048
	LYS11-12220A		1	51203001~
7	LYS11-12310	CROSS BAR	1	
8				
9				
10	S1055-01645	BOLT-HEX.	8	
11	S1055-01655	BOLT-HEX.	4	
12	S1055-01260	BOLT-HEX.	6	
13	S1055-01670	BOLT-HEX.	4	
14	S4512-50160	WASHER-SPRING	16	
15	S4512-50120	WASHER-SPRING	6	
16	S4012-50160	WASHER-PLAIN	16	
17	S4012-50120	WASHER-PLAIN	6	
18	S2056-50160	NUT-HEX.	8	
19	S2056-50120	NUT-HEX.	6	
20				
21				
22				

BOOM ASSEMBLY

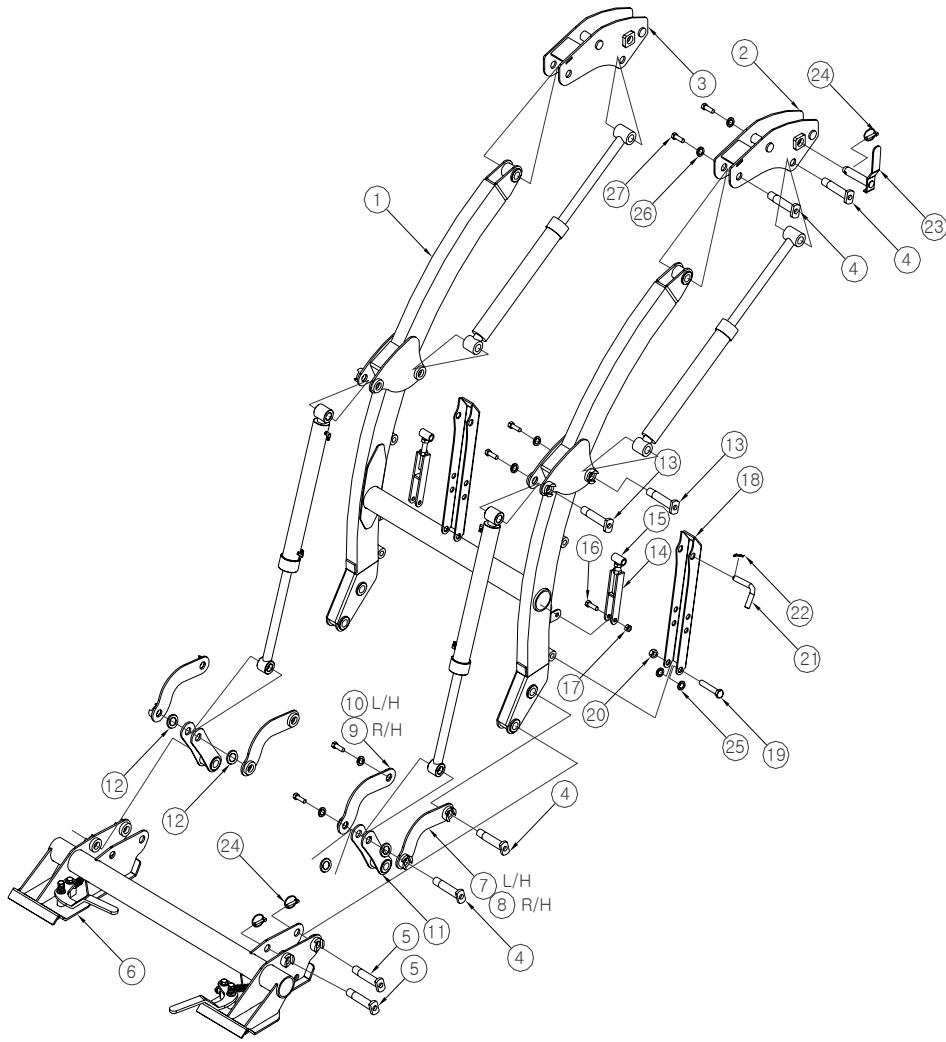

NO.	PART NO.	DESCRIPTION	Q'TY	SERIAL NO.
1	LTS16-11100	BOOM W.A	1	
2	LTS16-31100	TOP POST W.A-LH	1	~51005048
	LTS16-31100A	TOP POST W.A-LH	1	51203001~
3	LTS16-31200	TOP POST W.A-RH	1	~51005048
	LTS16-31200A	TOP POST W.A-RH	1	51203001~
4	CK11-0103	PIN	8	
5	CK11-0105	BUCKET-PIN	4	
6	LTS21-42000	QUICK ATTA. ASS'Y	1	
7	LTS16-51110	LINK W.A-BUCKET	1	
8	LTS16-51120	LINK W.A-BUCKET	1	
9	LTS16-51130	LINK W.A-BUCKET	1	
10	LTS16-51140	LINK W.A-BUCKET	1	
11	LTS16-52100	LINK W.A	2	
12	LTS16-71101	WASHER-PLAIN	8	
13	CK11-0104	PIN	4	
14	LTS16-61120	STAND W.A	2	
15	LTS21-61130	BOLT W.A	2	
16	S1056-51245	BOLT-HEX.	2	
17	1002-1263	NUT-SELFLOCK	2	
18	LTS16-61111	STAND	2	
19	S1056-51690	BOLT-HEX.	2	
20	1002-1673	NUT-SELFLOCK	2	
21	LTS16-61201	PIN-HAND	2	
22	S5515-51600	R-PIN	2	
23	LTS16-31501	PIN W.A	2	~51005048
	LTS16-31501A	PIN W.A	2	51203001~
24	1008-1001	RING PIN	6	
25	S4011-50160	WASHER-PLAIN	6	
26	CK11-0106	PIN-WASHET	8	
27	S1055-01020	BOLT	8	

HYDRAULIC PIPING

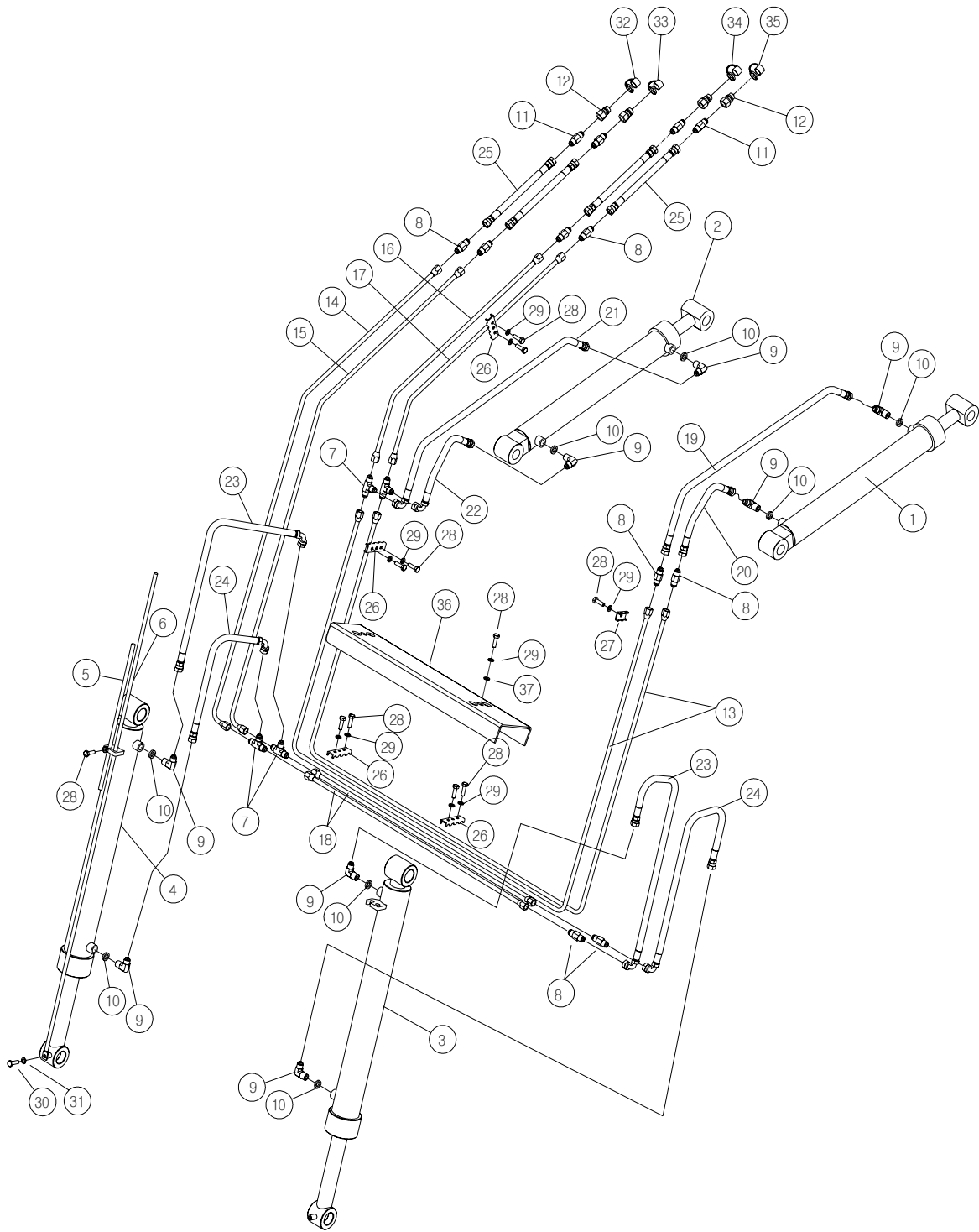

HYDRAULIC PIPING

NO	PART NO.	DESCRIPTION	Q'TY	SERIAL NO.
1	CK08-0200L-A	CYLINDER ASS'Y BOOM-LH	1	
2	CK08-0200R-A	CYLINDER ASS'Y BOOM-RH	1	
3	LTS16-82130	CYLINDER ASS'Y BUCKET-LH	1	
4	LTS16-82140	CYLINDER ASS'Y BUCKET-RH	1	
5	LTS16-81201	BAR. GAUGE-SHORT	1	
6	LTS16-81202	BAR. GAUGE-LONG	1	
7	LTS16-82401	NIPPLE, T-TYPE	4	
8	LTS16-82402	NIPPLE	6	
9	6004-0202	NIPPLE	8	
10	S4810-0P110	O-RING	8	
11	6003-0202	NIPPLE	4	
12	0001-1002	QUICK COUPLER-MALE	4	
13	LTS16-83510	PIPE ASS'Y	2	
14	LTS16-83520	PIPE ASS'Y	1	
15	LTS16-83530	PIPE ASS'Y	1	
16	LTS16-83540	PIPE ASS'Y	1	
17	LTS16-83550	PIPE ASS'Y	1	
18	LTS16-83560	PIPE ASS'Y	2	
19	LTS16-82610	HOSE ASS'Y	1	
20	LTS16-82620	HOSE ASS'Y	1	
21	LTS16-82630	HOSE ASS'Y	1	
22	LTS16-82640	HOSE ASS'Y	1	
23	LTS16-82650	HOSE ASS'Y	2	
24	LTS16-82660	HOSE ASS'Y	2	
25	LTS16-82670	HOSE ASS'Y	4	
26	LTL26-81801	CLAMP	4	
27	LTL26-81802	CLAMP	1	
28	S1053-50835	BOLT-HEX.	11	
29	S4013-50080	WASHER-SPRING	11	
30	S1053-51035	BOLT-HEX.	2	
31	S4013-50100	WASHER-SPRING	1	
32	SL045-48021	DUST CAP-RED FEMALE	1	
33	LTS21-81901	DUST CAP-BLUE FEMALE	1	
34	LTS21-81902	DUST CAP-YELLOW FEMALE	1	
35	0001-1003	DUST CAP-BLACK FEMALE	1	
36	LTS16-11200	PLATE, COVER	1	
37	S4013-50080	WASHER-PLAIN	2	

QUICK ATTACHMENT

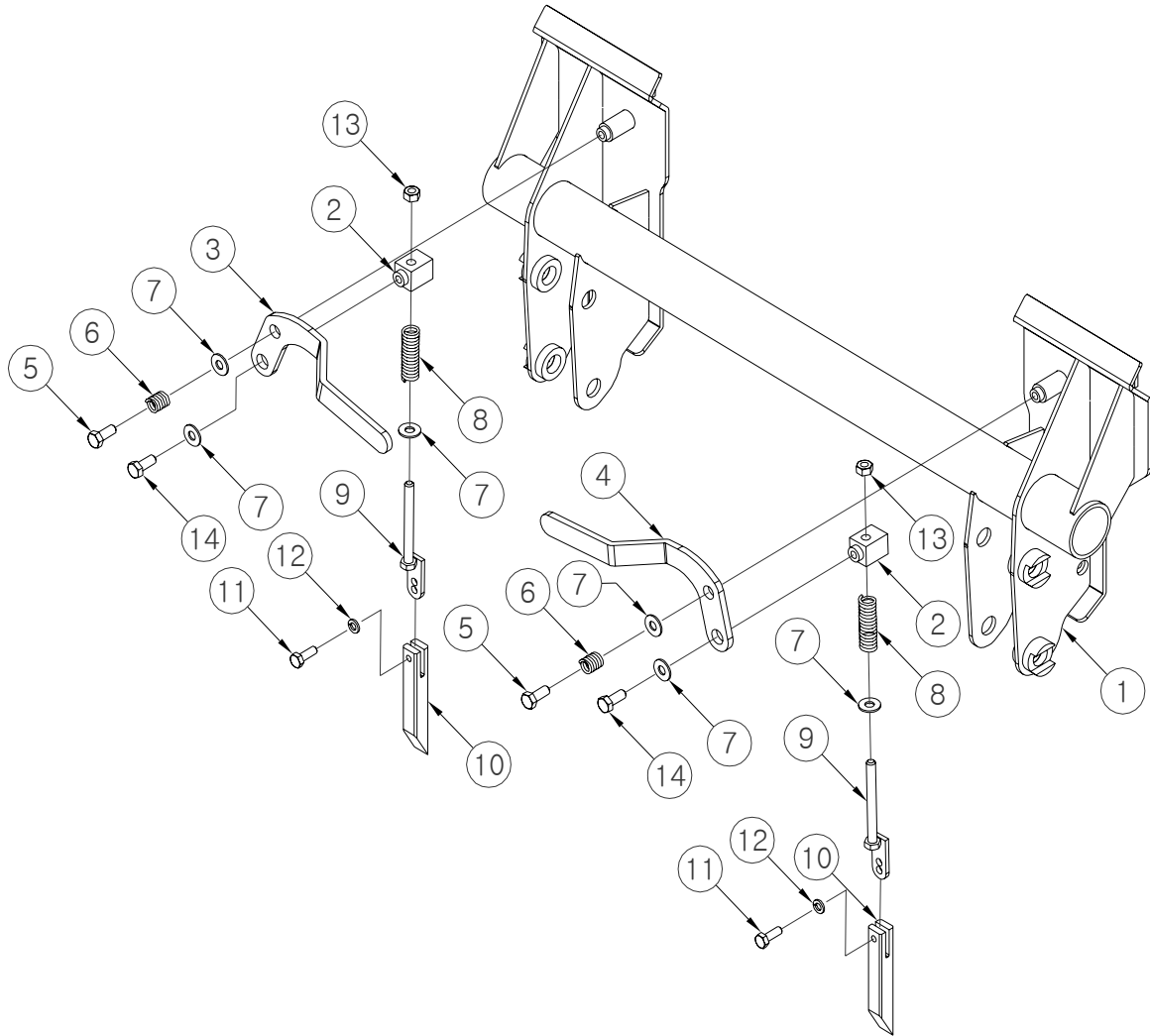

NO	PART NO.	DESCRIPTION	Q'TY	SERIAL NO.
-	KLD20-42000	QUICK ATTA. ASS'Y	-	
1	KLD20-42100	QUICK ATTA. W.A	1	
2	LTS21-42210	BAR-LINK	2	
3	KLD20-42232	HANDLE-LH	1	
4	KLD20-42231	HANDLE-RH	1	
5	S1056-51235	BOLT-HEX.	2	
6	PJ003-01030	SPRING	2	
7	S4011-50120	WASHER-PLAIN	6	
8	SL045-85233	SPRING	2	~51005048
	SL045-85233A	SPRING	2	51203001~
9	LTS21-42220	LINK W.A	2	
10	LTS21-42231	PIN-LOCK	2	
11	S1056-51030	BOLT-HEX.	2	
12	S4013-50100	WASHER-PLAIN	2	
13	S2056-50120	WASHER-PLAIN	2	
14	S1056-51220	BOLT-HEX.	2	

HYDRAULIC CONNECTING

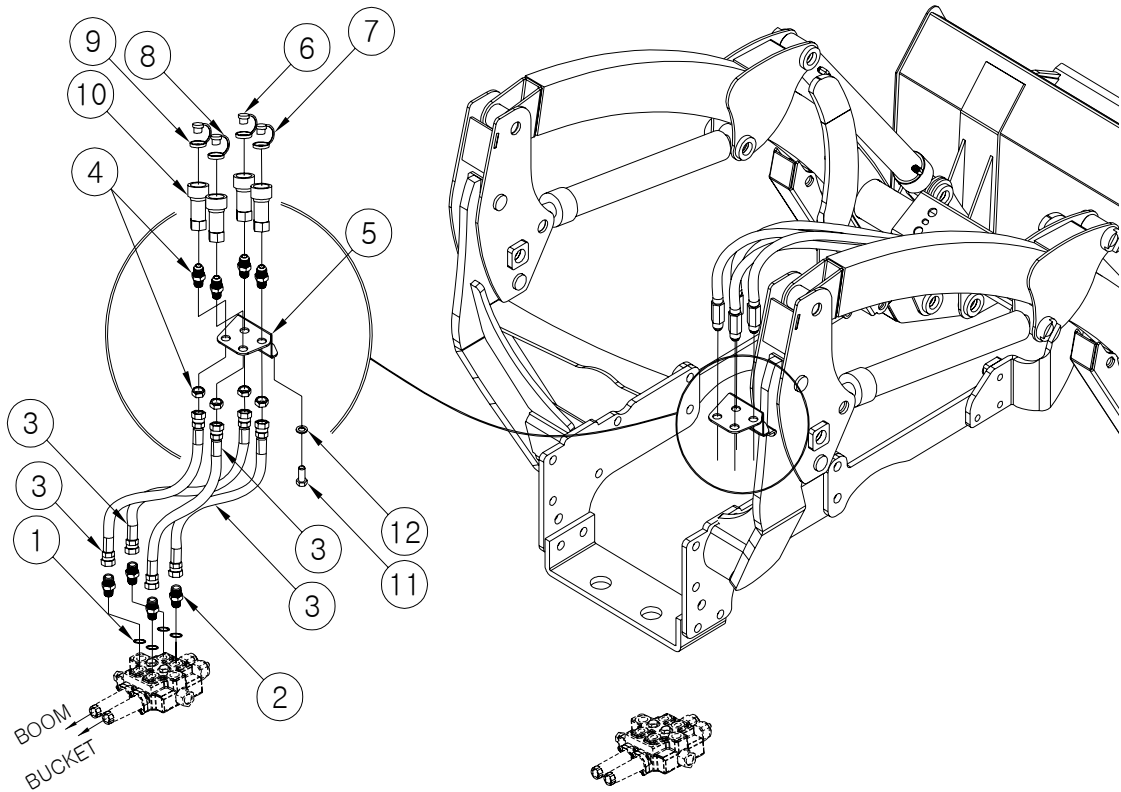

NO	PART NO.	DESCRIPTION	Q'TY	SERIAL NO.
1	2Q4691000	O-RING	4	
2	LTS16-82403	NIPPLE	2	
3	LTS16-82610	HOSE SET	4	
4	6003-0202	NIPPLE ASS'Y	4	
5	CK02-0117	BRACKET W.A	1	
6	0001-1004	DUST CAPS-BLACK MALE	1	
7	SLO45-48020	DUST CAPS-RED MALE	1	
8	LGM51-51101	DUST CAPS-BLUE MALE	1	
9	LGM51-51102	DUST CAPS-YELLOW MALE	1	
10	0001-1001	QUICK COUPLER-FEMALE	4	
11	S1055-51030	BOLT	2	
12	S4013-50100	PLAIN WASHER	2	

BOOM CYLINDER

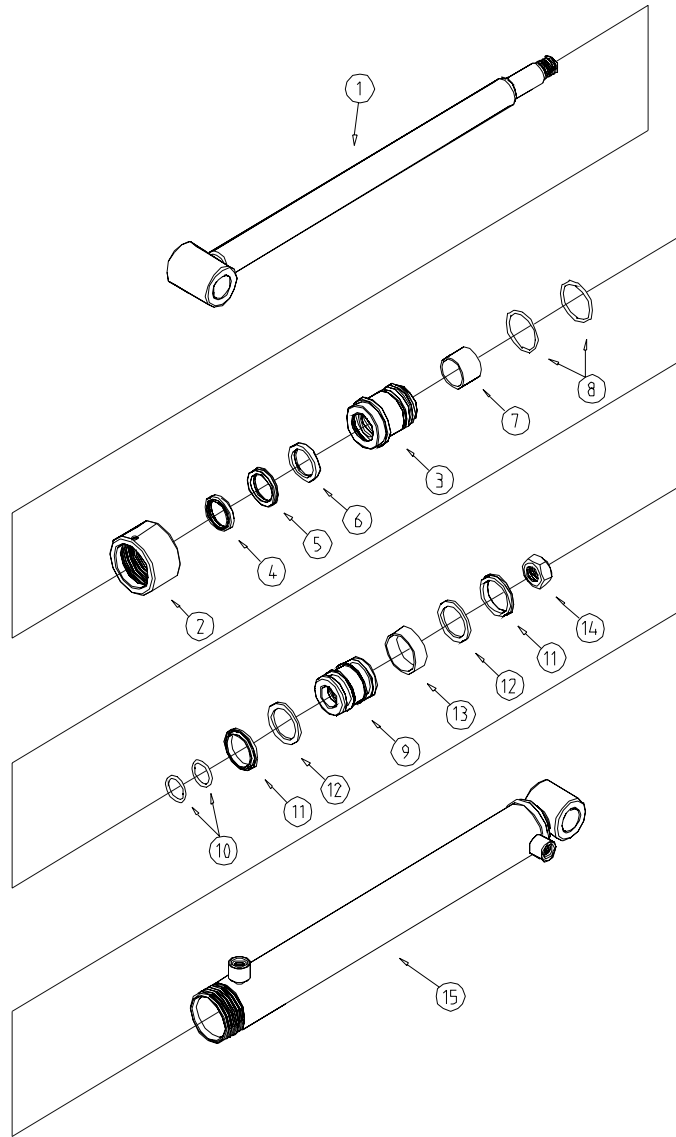

NO	PART NO.	DESCRIPTION	Q'TY	SERIAL NO.
1	CK08-0200L-A	BOOM CYLINDER ASS'Y-LH	1	
	CK08-0200R-A	BOOM CYLINDER ASS'Y-RH	1	
	2253-2100	ROAD ASS'Y	1	
2	OC45-5540	CAP, OUTER	1	
3	IC45-3060	COVER, INNER	1	
4	DSSD-R030	DUST	1	
5	UPSK-Y030	PACKING, U	1	
6	UPIS-I030	PACKING, U	1	
7	DU03-0025	BUSHING, DU	1	
8	OR1B-G040	O-RING	2	
9	PI45-2350	PISTON	1	
10	OR1B-G023	O-RING	2	
11	UPOS-I045	PACKING, U	2	
12	TRBR-0035	BACKUP RING	2	
13	WEWR-0045	WEARING	1	
14	NTP0-F032-D	NUT	1	
15	2253-1200	TUBE ASS'Y-LH	1	
	2253-2200	TUBE ASS'Y-RH	1	

BUCKET CYLINDER

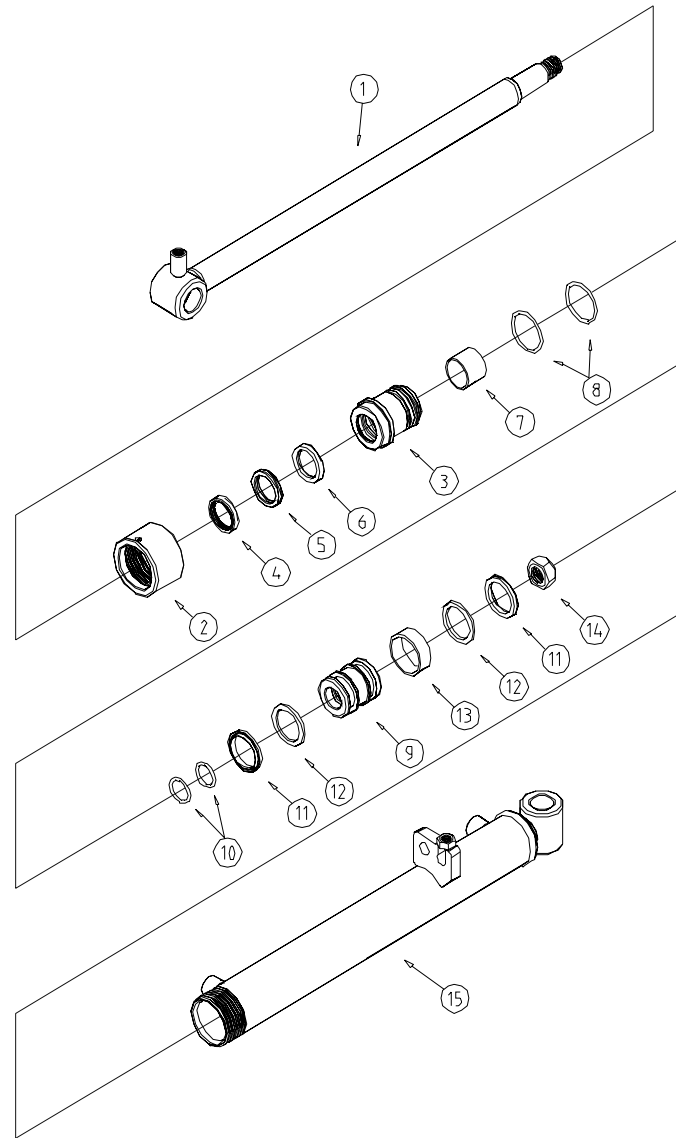

NO	PART NO.	DESCRIPTION	Q'TY	SERIAL NO.
-	LTS16-82130	CYLINDER ASS'Y, BUCKET-LH	-	
-	LTS16-82140	CYLINDER ASS'Y, BUCKET-RH	-	
1	2253-3100	ROAD ASS'Y	1	
2	OC45-5540	CAP, OUTER	1	
3	IC45-3060	COVER, INNER	1	
4	DSSD-R030	DUST	1	
5	UPSK-Y030	PACKING, U	1	
6	UPIS-I030	PACKING, U	1	
7	DU03-0025	BUSHING, DU	1	
8	OR1B-G040	O-RING	2	
9	PI45-2350	PISTON	1	
10	OR1B-G023	O-RING	2	
11	UPOS-I045	PACKING, U	2	
12	TRBR-0035	BACKUP RING	2	
13	WEWR-0045	WEARING	1	
14	NTP0-F032-D	NUT	1	
15	2253-3200	TUBE ASS'Y-LH	1	
	2253-4200	TUBE ASS'Y-RH	1	

DECALS



CAUTION :

Read and refer to the Tractor Operation Manual or Decals on the Tractor. and Loader Decals on as shown.

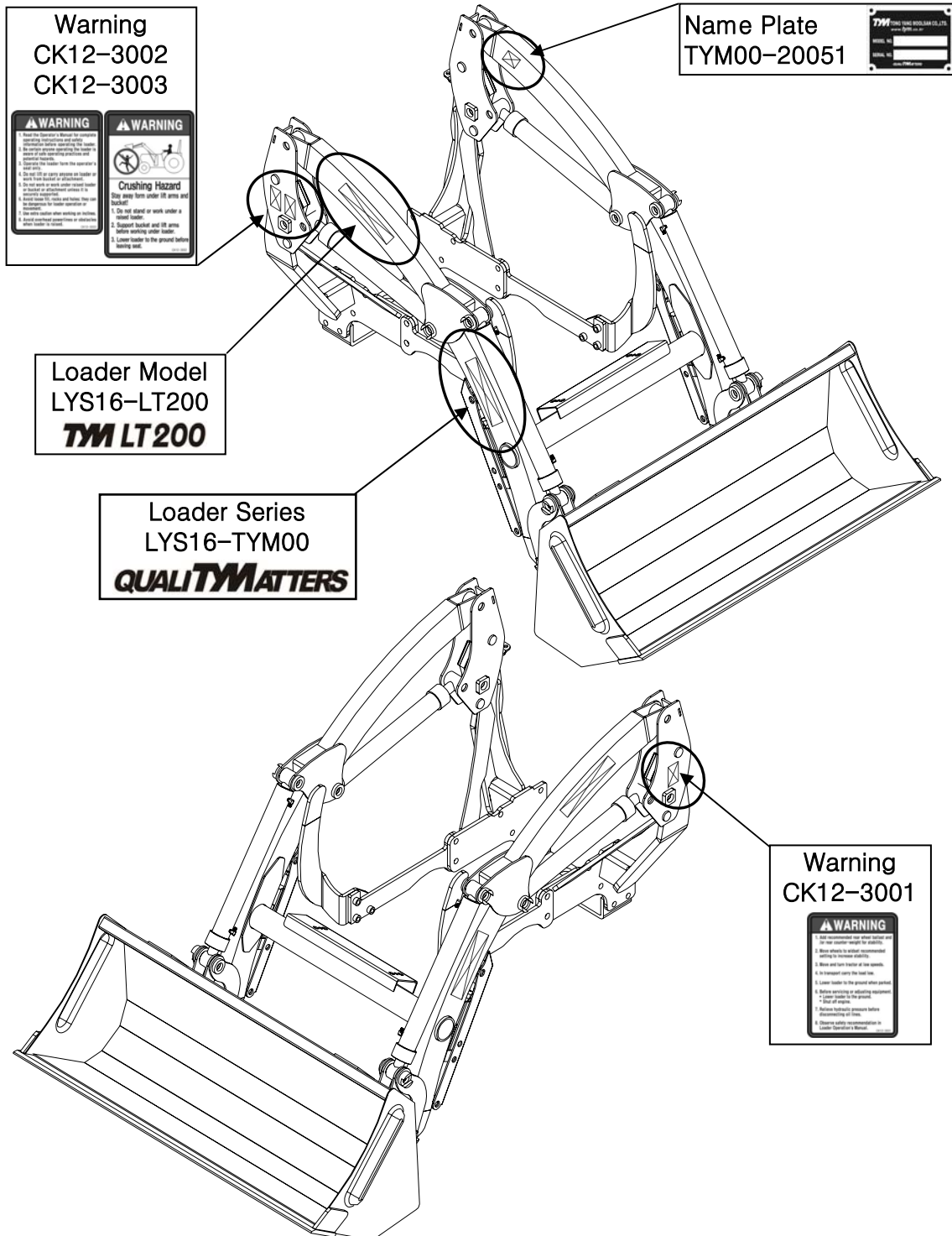

Refer to category "Safety decals"

LOADER INSTALLATION



CAUTION:

See your Loader Operator's manual for Safety Precautions and Tractor Preparations.

STEP 1. Position tractor on hard level surface.

STEP 2. Release loader, bucket and mount kit box from pallet.

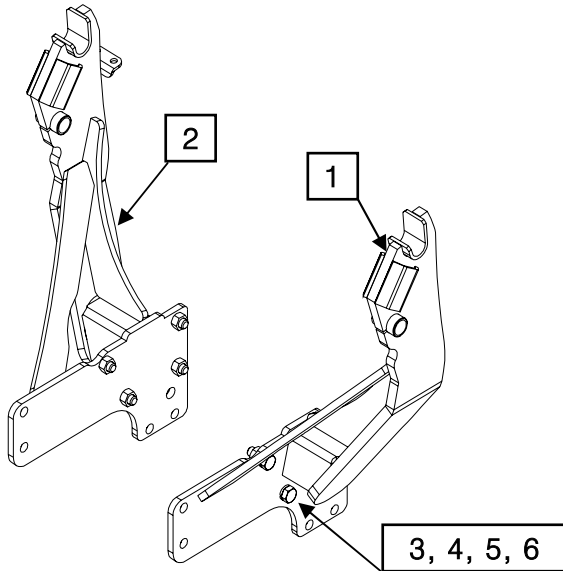

STEP 3. Install Mounting Frame-LH and Mounting Frame-RH.

- ① Mounting Frame-LH – 1EA
- ② Mounting Frame-RH – 1EA
- ③ Hex Head Bolt M16x2.0Px45L – 8EA
- ④ Spring Wahser \varnothing 16 – 8EA
- ⑤ Plain Wahser \varnothing 16 – 8EA
- ⑥ Hex Head nut M16x2.0P – 8EA

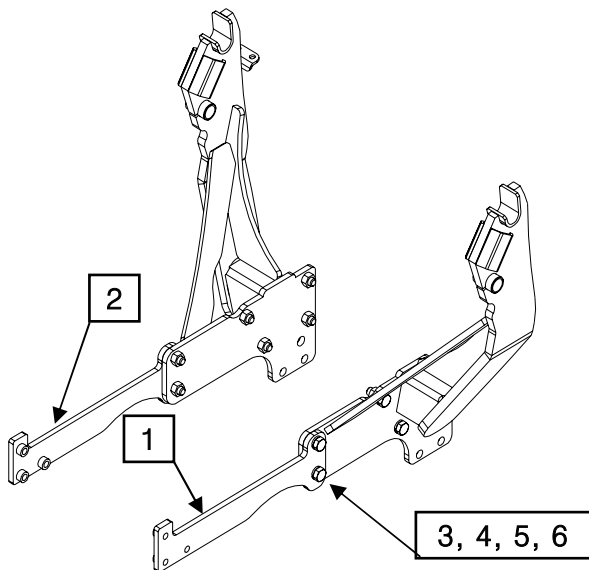

STEP 4. Install Grill Connector-LH and Grill Connector-RH.

- ① Grill Connector LH – 1EA
- ② Grill Connector RH – 1EA
- ③ Hex Head Bolt M16x2.0Px55L – 4EA
- ④ Hex Head nut M16x2.0P – 4EA
- ⑤ Spring Washer \varnothing 16 – 4EA
- ⑥ Plain Washer \varnothing 16 – 4EA

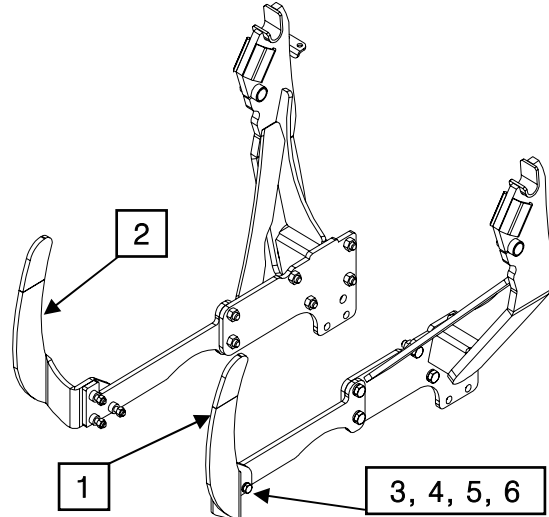

STEP 5. Install Front Grill

- ① Front Grill RH– 1EA
- ② Front Grill LH– 1EA
- ③ Hex Head Bolt M12x1.75Px60L – 6EA
- ④ Hex Head nut M12x1.75P – 6EA
- ⑤ Spring Washer \varnothing 12 – 6EA
- ⑥ Plain Washer \varnothing 12 – 6EA

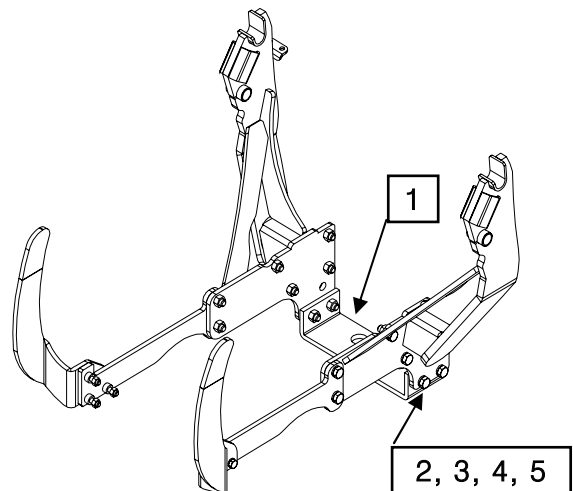

STEP 6. Install Cross Bar

- ① Cross Bar – 1EA
- ② Hex Head Bolt M16x2.0Px70L – 4EA
- ③ Hex Head nut M16x2.0P – 4EA
- ④ Spring Washer \varnothing 16 – 4EA
- ⑤ Plain Washer \varnothing 16 – 6EA

LOADER INSTALLATION

STEP 7. Install Boom Ass'y

Hang the groove on the pin located on Mounting Frame

